



INTENSIVE DISTRIBUTION TRANSPORT

TD

***Mechanical
steering system***



The mechanical steering system for your 1, 2 or 3-axle trailer

TD ADVANTAGES

- **SAVINGS ON PER-KILOMETRE COST PRICE**
- **TIME SAVINGS THROUGH BETTER ACCESSIBILITY**
- **MECHANICAL -> LOW-MAINTENANCE**

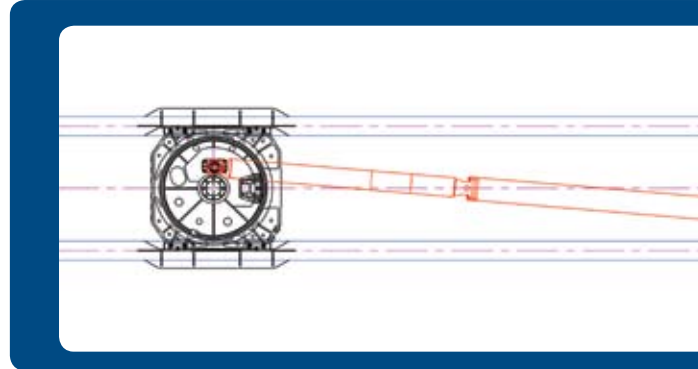

The TRIDEC TD steering system is a mechanical steering system used primarily in distribution transport. This system steers one axle of a one, two or three-axle trailer, but it can also steer two axles.

The TD steering system allows you to make more efficient use of your trailer. Through better manoeuvrability, the loading and unloading locations can be more easily serviced, inner cities are more accessible and roundabouts can be more easily driven.

The improved manoeuvrability of the vehicle results in better weight distribution of the load and results in even greater fuel savings. The time savings and reduction of the maintenance costs, fuel costs and tyre wear result in a lower cost price per kilometre (savings up to 30% possible).

The TD steering system is the most often sold steering system due to its effective design, easy installation, low price and minimal maintenance requirements.

Visit our website for additional information, and mail or call our sales

Tridec is an innovative company specialised in the development and manufacture of mechanical and hydraulic steering systems and axle suspension systems for all types of towed vehicles.

SAVINGS ON PER-KILOMETRE COST PRICE

Up to 30% cost reduction possible by saving on:

- Fuel consumption
- Tyre wear
- Vehicle maintenance
- Vehicle damage
- Damage to the surroundings

LONGER LIFESPAN OF TRAILER

TIME SAVINGS THROUGH BETTER ACCESSIBILITY

TIME SAVINGS / ACCESSIBILITY

- Better manoeuvrability
- Optimal stability
- Optimal tracking
- Optimal road handling
- Optimal flexibility of use

Environmentally-conscious

Noise reduction

Safety improvement

Improvement of driver comfort



TD TECHNOLOGY

MECHANICAL

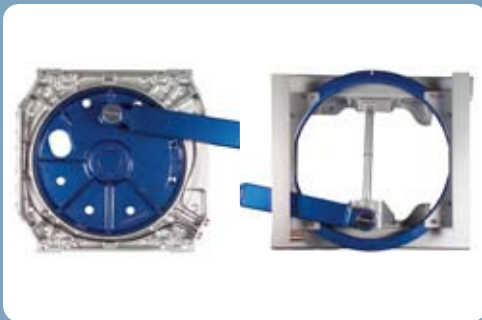
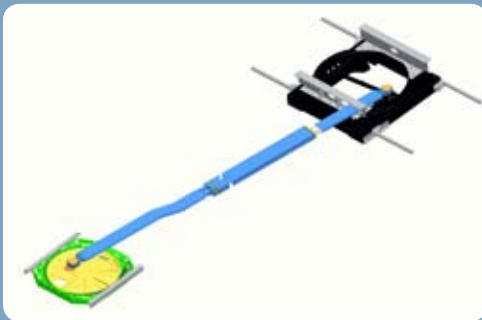
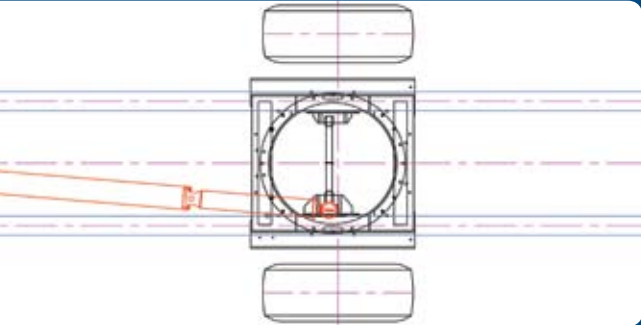

Due to its unique construction, the TD system has an extremely low weight and the required installation height of the fifth wheel plate is limited to 95 mm, so a low loading platform and a large internal volume can be achieved.

The TRIDEC TD system has been developed to make it suitable for every semi-trailer, as long as there is room for the steering rod.

The axle mounting frame is suitable for axles of various sizes from all the major manufacturers.

All TRIDEC products are custom-built, but we use standard components wherever possible so spare parts are always available. As an option, the system is also available with a central lubrication system.

Special versions

In addition to the standard TD system, our engineering department can also provide you with custom-tailored solutions. For more information, please contact our sales department.





INFO@TRIDEC.NL

WWW.TRIDEC.NL

T +31-(0)499-49 10 50

F +31-(0)499-49 10 60

TRIDEC BV

Transport industry development centre bv

Ekkersrijt 6030

5692 GA Son - Holland

T +31-(0)499-491050

F +31-(0)499-491060



**MGMT. SYS.
RvA C 029**

ISO 9001:2000

TRIDEC is ISO 9001:2000 certified.