

THE

NEW

STANDARD

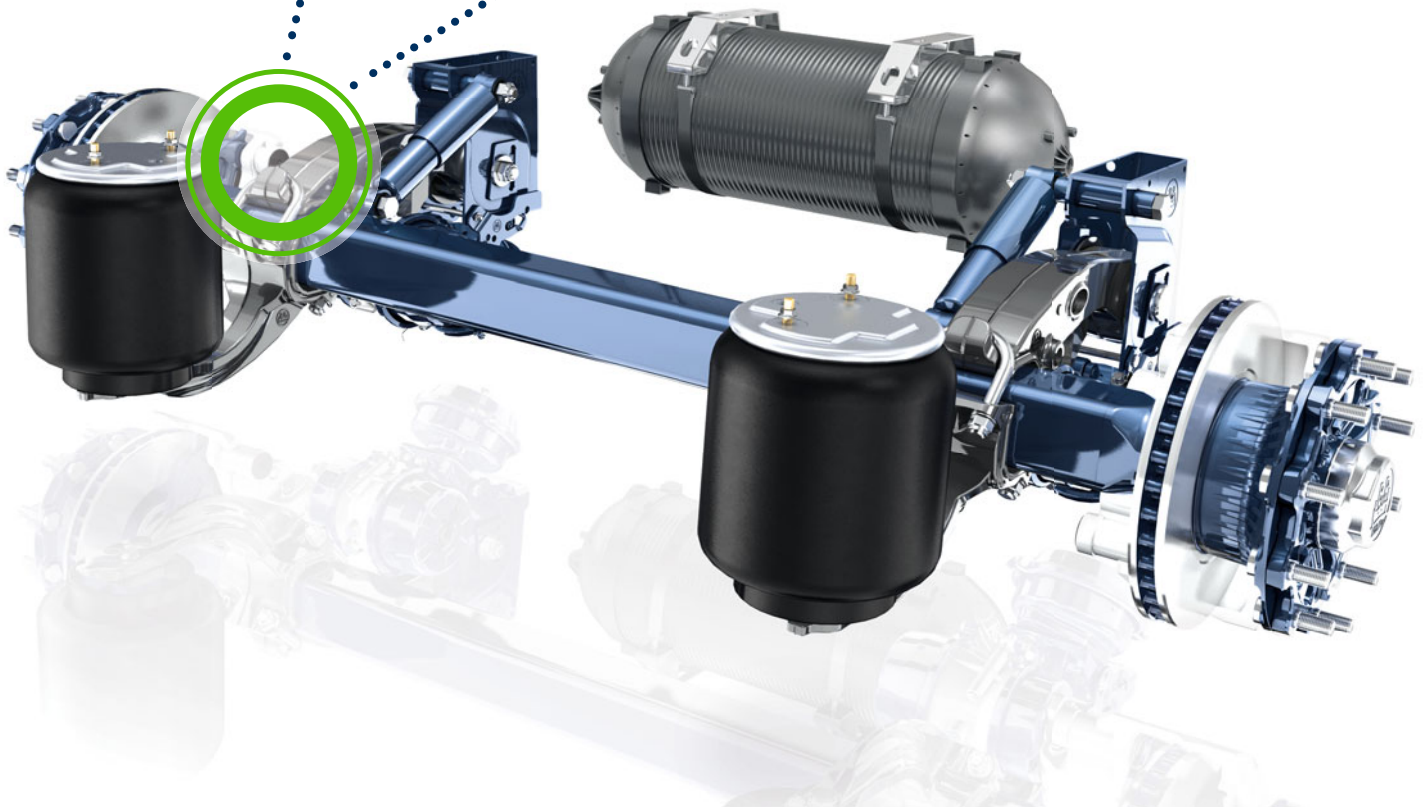

BPW ECO AIR COMPACT: FASTER, SIMPLER, LIGHTER

-60 %

Lower weight of the fibreglass reinforced plastic composite air tank compared with steel – for more loading capacity

-50 %

Reduced number of components – for a robust design and long life expectancy

-30 %

Fewer module versions – for more versatility

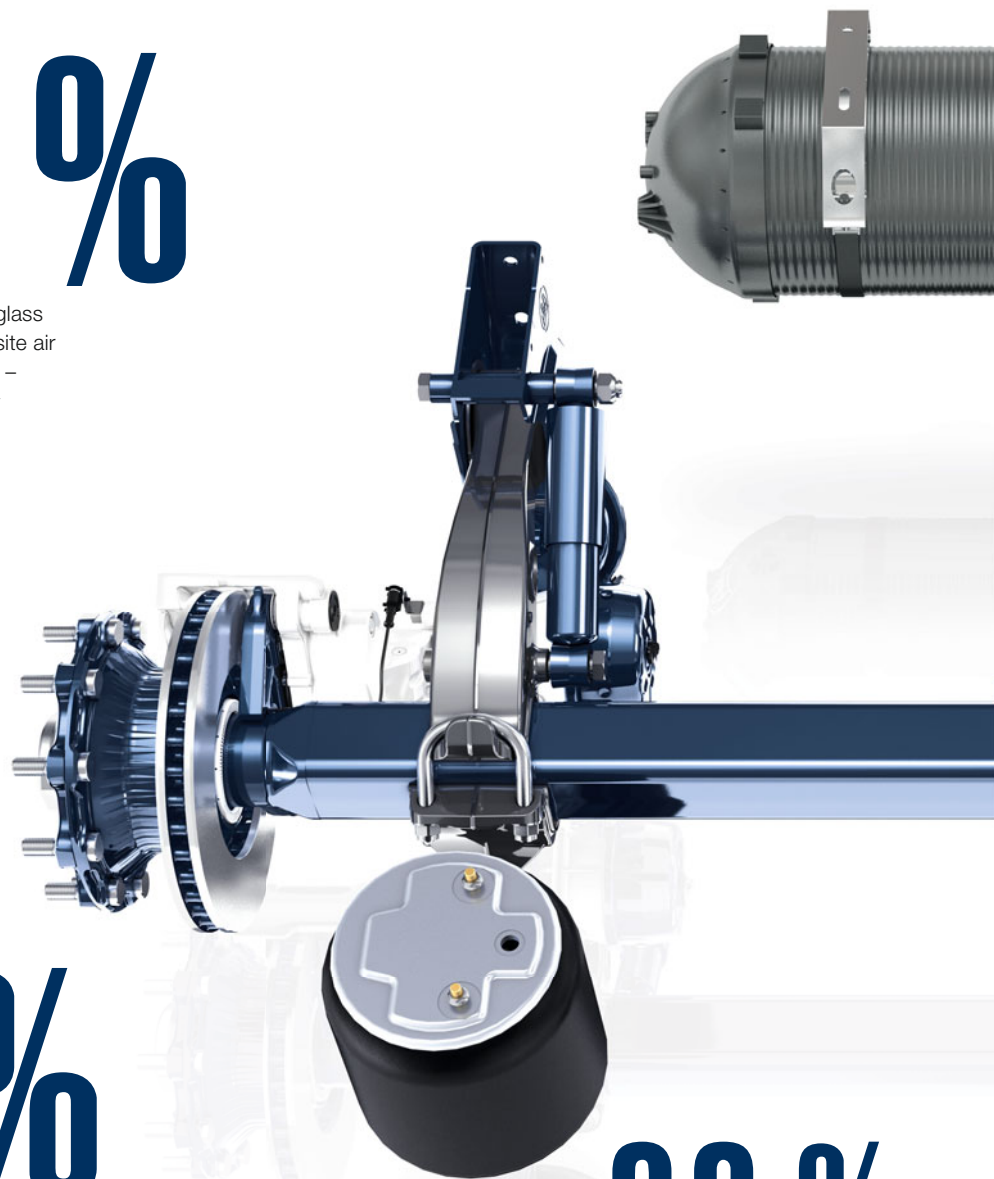

New modular ECO Air COMPACT air suspension plus new, light ECO Air composite air tanks – joined in an optimally coordinated system: that is the new standard for 9 tonne axles in on-road use. Every detail contains 100% BPW quality, cutting edge running gear know-how and a host of advantages. This is because innovative developments have rendered the system quicker, simpler and lighter in many areas. Whether in the trailer assembly, on the road or later when it comes to maintenance: ECO Air COMPACT is guaranteed to provide more cost-effectiveness every time and everywhere.



-50 %

Less expenditure of resources due to redesigned axle lift – for shorter assembly time

100 %

Maintenance-free spring seat arrangement – for reduced operating costs

COST-EFFECTIVENESS IN EVERY DETAIL

The new ECO Air COMPACT was designed for leaner production processes at the vehicle manufacturer. The trailer assembly has thus been optimised even more: fewer versions and reduced assembly costs save time, effort and also costs. And freight forwarders also benefit too: as the system, including the ECO Air composite air tank, is completely maintenance-free and components can be replaced in a modular manner. This is ensured by innovative details such as diagonal screwed joints or the special steel-rubber-bush for long life expectancy – which therefore ensures that the trailer is continuously and economically in use.

NEW MODULAR CONCEPT

The ECO Air COMPACT suspension is mounted on a two-part cast member and the new steel-rubber-bush. With fewer components this innovative technology makes the ECO Air COMPACT particularly robust. This is because the optimum transfer of forces is ensured by the diagonal screwed joints combined with the four points of support. An additional advantage is that the individual components are not welded and can therefore be easily replaced.

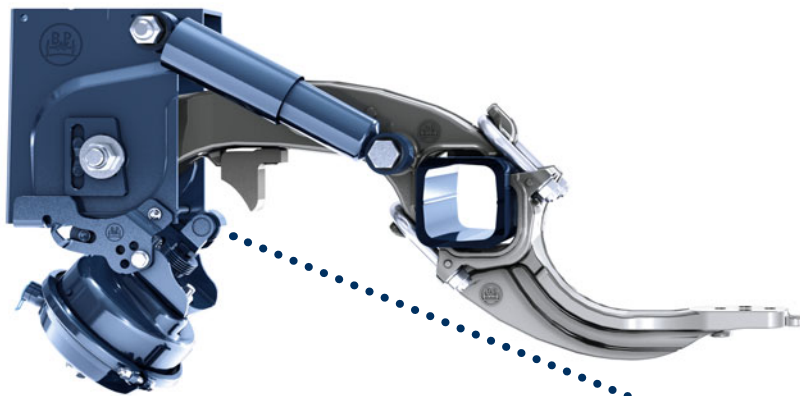

Your advantages at a glance

- 30% fewer module versions for more flexibility
- 50% reduced assembly time through re-designed axle lift
- 50% lower number of components for a robust design and long life expectancy
- 100% maintenance-free spring seat arrangement reduces operating costs
- 60% lighter fibreglass reinforced plastic composite air tanks for more loading capacity

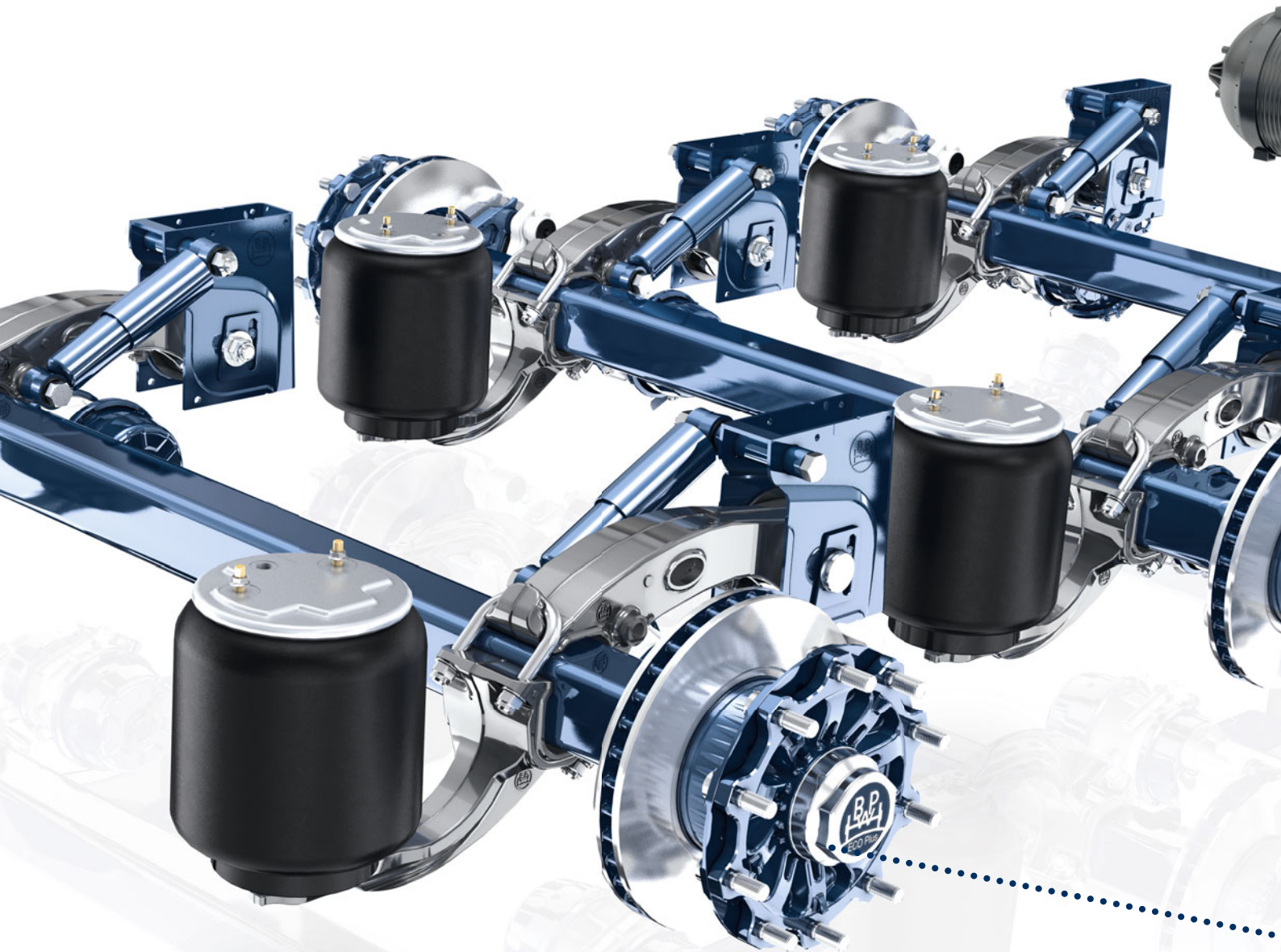

NEW STEEL-RUBBER-BUSH

The specially designed steel-rubber-bush is asymmetrical, can handle all demands placed on it and is designed without any recesses. Its optimised axial and vertical track guidance helps contribute towards high operating comfort and lower tyre wear. Consistent load absorption as well as even deformation ensure smooth operating and long life expectancy.

NEW ECO AIR COMPOSITE AIR TANK

The new ECO Air fibreglass reinforced plastic composite air tanks offer a reduction in weight of up to 60% in comparison with steel compressed air tanks (at 2 x 60 litres). The high-tech composite materials, together with the patented production process, ensure long life expectancy.

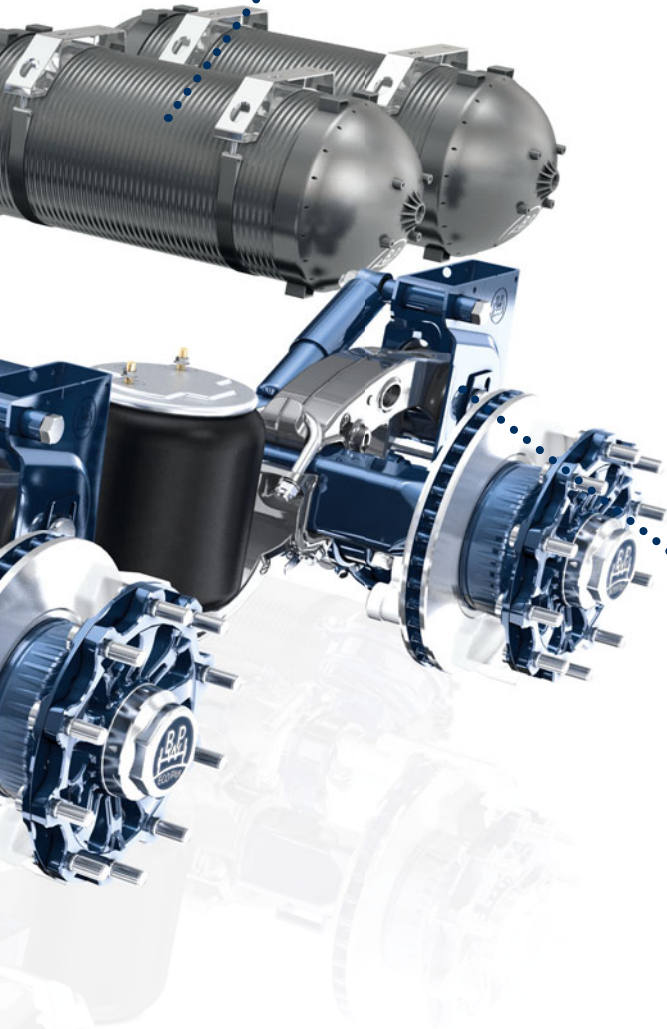

NEW DOUBLE-SIDED AXLE LIFT

A pre-mounted unit with counter-holder is secured to a support or cast member in a few simple assembly moves. That reduces the assembly costs by 50% when compared with air suspensions.



ECO PLUS GUARANTEE

5+3 years with unlimited mileage –
for safety throughout Europe

FEWER COMPONENTS EQUALS HIGHER COST-EFFECTIVENESS

ECO Air COMPACT is designed for on-road use with 9 tonne axles – suitable for drum and disc brakes. Nothing else is needed: the modular product construction kit only now contains 2 supports, 2 suspension arms and 3 bellows brackets. Fewer components reduces the lay-out complexity - and helps to lower storage and production costs.

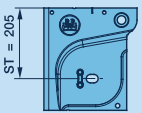
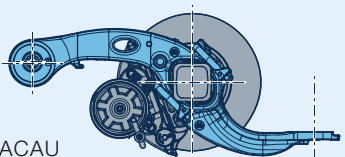
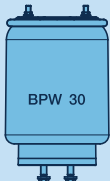
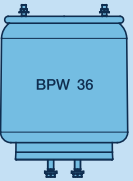
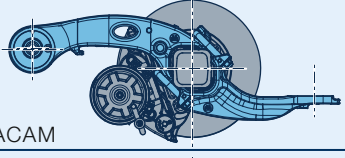
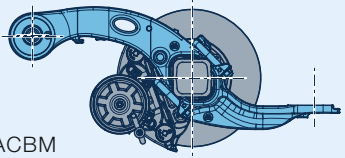
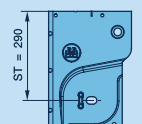
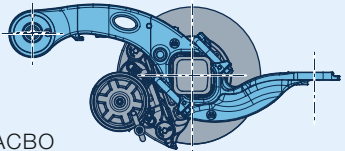
Suspension ECO Air COMPACT (AC)			
Leer ohne Luft	Connecting pieces	Versions	Bellows
145 – 175		 ACAU	 
185 – 215		 ACAM	
240		 ACBM	
270 – 300		 ACBO	
330 – 390			

Axle 120x10		Options
ET 0	ET 120	Double-sided lift Kombi air bag for rail loading Long stroke bellows
Drum brake	Disc brake	
SN 4218	TSB 3709	
	TSB 4309	

ECO Air composite tank versions* (incl. attachment)							
Volume	Diameter	Length	Weight	Volume	Diameter	Length	Weight
30 l	276 mm	628 mm	5.4 kg	60 l	396 mm	650 mm	9.2 kg
40 l	276 mm	807 mm	6.4 kg	80 l	396 mm	824 mm	10.9 kg
60 l	276 mm	1077 mm	7.6 kg	100 l	396 mm	999 mm	12.7 kg
60 l	310 mm	960 mm	9.6 kg	120 l	396 mm	1173 mm	14.8 kg

*Further versions are available upon request



BPW-ECO Air Compact 15191202 e

RTS-RIEGELTEAM.DE

WE GO THE ECONOMICAL WAY!

BPW is a globally leading manufacturer of intelligent running gear systems for drawbar trailers and semi-trailers. From the axle via the suspension and brake to the electronic braking system and user-friendly telematics applications for efficient fleet management, we can provide you with complete one-stop trailer running gear supplies. As an owner-managed company, BPW is consistently focused on one goal: to always offer you precisely the solution which pays off for you in the end. In line with this, we focus on total quality to ensure high reliability and life expectancy, weight- and time-saving designs ensuring lower operating and maintenance costs as well as personalised customer service and a tight-knit service network to provide quick and direct support. You can rest assured that with BPW you are always following the economical route.

BPW Bergische Achsen Kommanditgesellschaft

Postfach 12 80 · 51656 Wiehl, Germany · Phone +49 (0) 2262 78-0
info@bpw.de · www.bpw.de

